

EnergiVm

CE  MH 28269

MV628(6V2.8Ah)

PHYSICAL SPECIFICATION

Nominal Voltage Nominal Capacity (20HR)		6V 2.8Ah
Dimension	Length	66 1mm (2.60 inches)
	Width	34 1mm (1.34 inches)
	Container Height	99 1mm (3.90 inches)
	Total Height	104 1mm (4.09 inches)
Weight		Approx. 0.59Kg (1.30lbs)
Standard Terminal		Fasten Tab No.187E

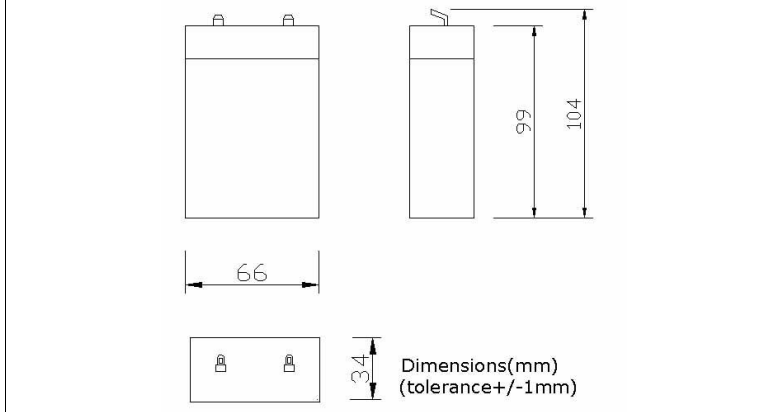

F1(Fasten Tab No.187E)
Standard Terminal

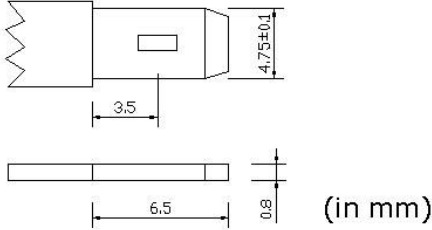

ELECTRICAL SPECIFICATION

Characteristics		
Capacity	20 hour rate (0.14A)	2.8Ah
	10 hour rate (0.25A)	2.7Ah
	5 hour rate (0.48A)	2.4Ah
	1hour rate (1.68A)	1.7Ah
Capacity affected by temperature	40°C (104 °F)	102%
	25°C (77 °F)	100%
	0°C (32 °F)	85%
Internal Resistance	Full charged battery (25°C,77 °F) 30mΩ	
Constant Voltage Charge	Cycle	Initial Charging Current less than 0.84A Voltage 7.20~7.50V at 25°C (77 °F) Temperature Coefficient -15mV/°C
	Standby	No limit on Initial Charging Current Voltage 6.75~6.90V at 25°C (77 °F) Temperature Coefficient -10mV/°C

