

**RS-232 ↔ RS-485  
INTERFACE CONVERTER  
IC-485S  
&  
IC-485SI**

**User's Manual**

@Copyright 1994 ATEN® International CO., LTD.  
Manual part NO.PAPE-0075-200  
Printed in Taiwan 06/94

## PACKAGE CHECKLIST

When you purchase this product, it should contain the following elements:

- IC-485S or IC-485SI Converter x 1
- Power Adapter (DC9V, 200mA) x 1
- IC-485S & IC-485SI User's Manual x 1

**Attention:** To prevent electric shock caused by lightening, you must provide a ground path by connecting a wire from the **Grounding Tab** to the earth ground (for IC-485SI only).

## TABLE OF CONTENTS

<b>1 FUNCTION OVERVIEW</b> .....	1
1-1 Introduction .....	1
1-2 Specifications. ....	2
<b>2 INSTALLATION</b> .....	3
2- 1 Installation Procedure. ....	3
2-2 Switch Function Description .....	4
<b>3 OPERATION</b> .....	6
3-1 Point-to-Point/4-Wire Full Duplex ....	8
3-2 Point-to-Point/2-Wire Half Duplex ....	9
3-3 Multidrop/4-Wire Full Duplex. ....	10
3-4 Multidrop/2-Wire Half Duplex .....	11
3-5 Simplex/Transmit, Receive Only. ....	12
3-6 Monitoring (for IC-485s only) ....	13
<b>4 OTHERS</b> .....	14
4- 1 Terminal Block Definition. ....	14
4-2 Self Test .....	15
<b>APPENDIX A</b>	
Trouble Shooting .....	16
RS-232 DCE/DTE Description .....	17
Preventing Radio & TV Interference. ....	18

## 1 FUNCTION OVERVIEW

### 1-1 INTRODUCTION

The IC-485S and IC-485SI are a series of a bi-directional interface converters for RS-232 and RS-485. The IC-485SI has built-in isolators for high voltage (2000V) protection. With the IC-485 series, ic-485s & IC-485SI, it provides Point-to-Point, Multidrop and Simplex operations. The IC-485s provides an extra Monitoring function.

The IC-485 can be powered from the following two ways:

- 1) a DC 9V, 200mA power adapter
- 2) the pin #9 of the RS-232 connector

Two slide switches are used to configure its operation mode, contention control, and assignment of the RS-232. Following figure is the IC-485's external view.

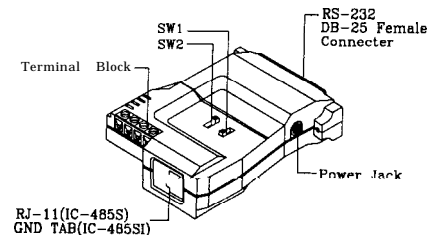

Figure 1-1 External View

## 1-2 SPECIFICATIONS

FUNCTION	SPECIFICATIONS
Power Supply	DC9V, 200mA
Data Rate	Up to 100K bps under 4000 ft.(1.2Km)
Isolation (IC-485SI only)	Up to 2000V AC
Connector	RS-232:DB-25 Female RS-485/422: A 4 terminal block and RJ-11* or GND TAB**
Function Switch	SW1:DCE,DTE, MONITOR** selection SW2:TxON, RxON SW2:TxRTS, RxRTS SW2:TxRTS, RxON
Enclosure	Plastic
Weight	60 gm
Dimensions	54x74.5x18.5mm

Figure 1-2 IC-485 Specifications Table

\* RJ-11 Connector & Monitor mode for IC-485S only.

\*\* **Grounding TAB** for IC-485SI only.

## 2 INSTALLATION

### 2-1 INSTALLATION PROCEDURE

Before installing the IC-485 you will need a 4-wire cable. This cable must go from your location to the place you want to connect to.

Installation Procedure:

- 1 Before installing the IC-485 to the PC, decide one of the 6 possible configurations suitable for your application. Please check Chapter 3 OPERATION for correct slide switch settings and phone wires connection, then connect IC-485 to the PC.

For IC-485SI: Connect a wire from the Grounding Tab to the earth ground.

2. Turn on PCs.
3. Insert the adapter's plug into the POWER JACK in the right side.
4. Plug the power adapter into an AC outlet. The unit is now ready for operation.

## 2-2 SWITCH FUNCTION DESCRIPTION

Refer to the location of the SW1 and SW2, please see Figure 1- 1.

IC-485S:

Position	SW1	SW2
1	DCE	TxON, RxON
2	DTE	TxRTS, RxRTS
3	Monitor	TxTRS, RxON

IC-485SI:

Position	SW1	SW2
1	DCE	TxON, RxON
2	DTE	TxRTS, RxRTS
3	X	TxRTS, RxON

### SW 1: Device Mode Selection

Position 1: DCE means the IC-485 is set at DCE mode and it must be connected to a DTE device.

Position 2: DTE means the IC-485 is set at DTE mode and it must be connected to a DCE device.

Position 3: Monitor means the IC-485S is set at monitor mode and it is used to monitor

the RS-485 line signals (for IC-485S only).

### SW2: Transmitting and Receiving mode selection

Position 1: (TxON, RxON) means the IC-485 is always in transmitting mode and in receiving mode.(using in Point-to-Point mode)

Position 2: (TxRTS, RxRTS) means the K-485 is in transmitting mode while RTS signal is at high level and it is in receiving mode while RTS signal is at low level.(using in Multidrop mode)

Position 3: (TxRTS, RxON) means the IC-485 is always in receiving mode and it is in transmitting mode only while RTS signal is at high level.(using in Multidrop mode to monitor the RS-485 line signals)

**Note:** DTE means Data Terminal Equipment.  
DCE means Data Communication Equipment.  
More detailed information, please refer to the Appendix.

### 3 OPERATION

The IC-485S & IC-485SI supports 4 kinds of functions in 6 kinds of configurations. They are

#### 1. Point-to-Point

Point-to-Point configuration means two devices which locate at two different places can be linked together to communicate through a couple of IC-485 devices.

1.1 Point-to-Point/4-Wire Full Duplex( Fig. 3- 1 )

1.2 Point-to-Point/2-Wire Half Duplex( Fig. 3-2 )

#### 2. Multidrop

Multidrop configuration means that more than two devices can be linked all together to communicate one another through many IC-485 devices. In this configuration, one of the IC-485 devices will be connected to a master device and the rest of IC-485 devices will be connected to many other slaver devices.

2.1 Multidrop/4-Wire Full Duplex( Fig. 3-3 )

2.2 Multidrop/2-Wire Half Duplex( Fig. 3-4 )

#### 3. Simplex/Transmit, Receive Only( Fig. 3-5 )

Simplex configuration means that more than two devices can be linked all together to communicate through many IC-485 devices. Its configuration is like the Multidrop's, but the master device can talk only and the slaver devices can listen only.

#### 4. Monitor **Mode**( Fig. 3-6 ) (for IC-485S only)

Monitor configuration means a IC-485s device can be wired to the lines of RS-485 or RS-422 devices to monitor the line signals. In this configuration the IC-485S will change the function of T+ and T- to R'+ and P' respectively

Before operating, user must complete the installation according to the procedure mentioned in Section 2- 1

Once the installation had been done, the device should operate as the setting function.

**3-1 POINT-TO-POINT/4-WIRE FULL DUPLEX**

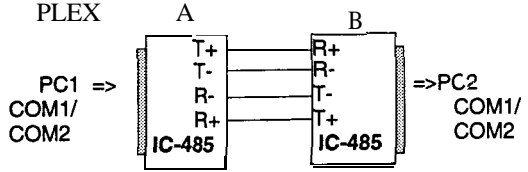

Configuration:

Device	SW1	SW2
A	DCE/DTE	TxON, RxON
B	DCE/DTE	TxON, RxON

Figure 3-1 POINT-TO-POINT/4-WIRE FULL DUPLEX

In above Figure if the PC 1 is a DTE device, then the Device A should set the SW1 to DCE. If the PC1 is a DCE device, then the Device A should set the SW1 to DTE. The switch setting method for the Device B is identical to Device A's.

Note: All the SW1 setting in this Chapter are following the setting rule indicated in this Section.

**3-2 POINT-TO-POINT/2-WIRE HALF DUPLEX**

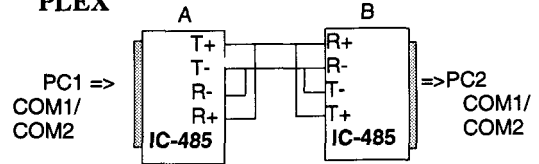

Configuration:

Device	SW1	SW2
A	DCE/DTE	TxRTS, RxRTS
B	DCE/DTE	TxRTS, RxRTS

Figure 3-2 POINT-TO-POINT/2-WIRE HALF DUPLEX

## 3-3 MULTIDROP/4-WIRE FULL DUPLEX

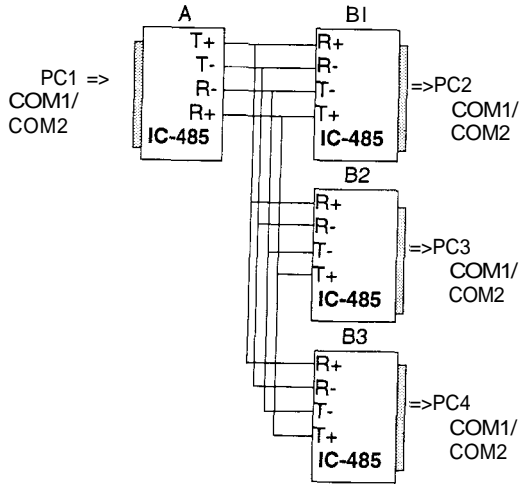

Configuration:

Device	SW1	SW2
A	DCE/DTE	TxON, RxON
Bn	DCE/DTE	TxRTS, RxON

Note: Bn means any one of the B 1, B2, B3 and so on.

Figure 3-3 MULTIDROP/4-WIRE FULL DUPLEX

## 3-4 MULTIDROP/2-WIRE HALF DUPLEX

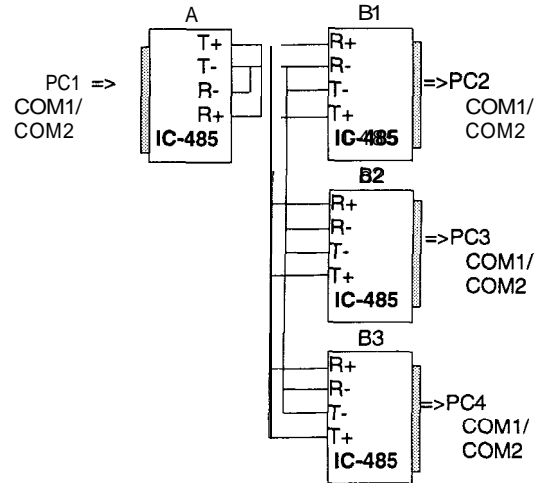

Configuration:

Device	SW1	SW2
A	DCE/DTE	TxRTS, RxRTS
B	DCE/DTE	TxRTS, RxRTS

Note: Bn means any one of the B 1, B2, B3 and so on.

Figure 3-4 MULTIDROP/2-WIRE HALF DUPLEX



3-5 SIMPLEX/ TRANSMIT, RECEIVE ONLY

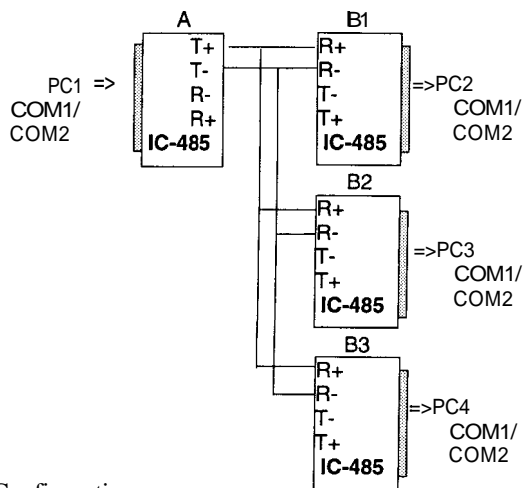

Configuration:

Device	SW1	SW2
A	DCE/DTE	TxON, RxON
Bn	DCE/DTE	TxON, RxON

Note: Bn means any one of the B 1, B2, B3 and so on.

Figure 3-5 SIMPLEX/TRANSMIT, REC-EIVE ONLY

3-6 MONITORING (for IC-485S only)

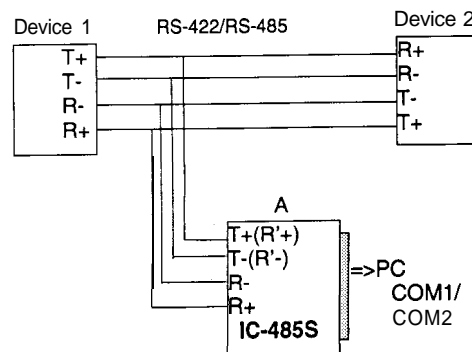

Note: R+ and R- signals are converted and linked to the RS-232 port, DB-25 pm 3. R' + and R' - (T+ and T-) signals are converted and linked to the RS-232 port, DB-25 pm 2.

Configuration:

Device	SW1	SW2
A	MONI	TxRTS, RxON

Note: The RTS must be at the low level in monitoring mode.

Figure 3-6 MONITORING

## 4 OTHERS

### 4-1 TERMINAL BLOCK DEFINITION

The four screw terminal block has different definition in different operation modes.

In the DCE/DTE mode, the terminal #1 (+V) and #2(-V) are configured to transmit data, the transmitter; the terminals #3(-V) and #4(+V) are configured to receive data, the receiver.

In the MONITOR mode (for IC-485S only), the terminals #1 and #2 are respectively the positive and negative of receiver #1; the terminal #3 and #4 are the positive and negative of receiver #2.

PIN #	DCE/DTE	
1	Transmitter + V	Receiver # 1 + V
2	Transmitter - V	Receiver # 1 - V
3	Receiver - V	Receiver # 2 - V
4	Receiver + V	Receiver # 2 + V

Figure 4-1 Terminal Block

### 4-2 SELF TEST

To test the internal circuit of the interface converter, connect a dumb terminal to the unit and process as follows:

1. Set SW1 to DCE (if the dumb terminal is a DTE configuration).
2. Set SW2 to TxON, RxON.
3. Connect one wire from Tx+(#1) to Rx+(#4), and connect another wire from Tx-(#2) to Rx-(#3).
4. Set the terminal to full duplex and enter data, then the data should be displayed on the screen.
5. If this occurs the internal circuit is operational.

## APPENDIX A

### TROUBLE SHOOTING

PROBLEMS	SOLUTIONS
Failure of data transmission	<ol style="list-style-type: none"> <li>1. Check that the DC Power Adapter is available.</li> <li>2. Check that the IC-485 is plugged securely in PC.</li> <li>3. Check that the 4-wire cable is connected properly at both ends.</li> <li>4. Check that the SW1, SW2 are set properly.</li> </ol>
Data Loss or Error	Check that the data rate, data format are the same for both Devices.

If failure of printing is still exists upon aforesaid solutions, please contact your dealer for help.

### RS-232 DCE/DTE DESCRIPTION

Device's Connector Pin #				Cables	IC-485	
DCE DB-9	DTE DB-9	DCE DB-25	DTE DB-25	25/25 or 9/25 PIN	DCE DB-25	DTE DB-25
2	3	3	2	Tx → Rx	2	3
3	2	2	3	Rx ← Tx	3	2
8	7	5	4	RTS → CTS	4	5
7	8	4	5	CTS → RTS	5	4
5	5	7	7	GND	7	7

Note: The DTE mode device must be connected to a DCE mode device because the polarity of the communication signals are different. The shadow area is a connection example for a DTE device to a DCE device.

## PREVENTING RADIO & TV INTERFERENCE

Warning this equipment generates, uses and radiates radio frequency energy and if not installed and used in accordance with the instruction manual may cause interference to radio and television reception. It has been tested and found to comply with the limits for a Class A computing device in accordance with the specifications in Subpart J of Part 15 of FCC Rules, which are designed to provide reasonable protection against such interference when operated in a commercial environment. Operation of this equipment in a residential area is likely to cause interference, in which case the user at his own expense will be required to take whatever measures may be required to correct the interference.

If this equipment does cause interference to radio or television reception, which can be determined by turning the equipment off and on, the user is encouraged to try to correct the interference by one or more of the following measures:

1. Reorient the receiving antenna.
2. Relocate the computer with respect to the receiver.

3. Move the computer away from the receiver.
4. Plug the computer into a different outlet so that computer and receiver are on different branch circuits.
5. Ensure that the mounting screws, attachment connector screws and ground wires are tightly secured.
6. Ensure that good quality, shielded and grounded cables are used for data communications.

If necessary, the user should consult the dealer or an experienced radio/television technician for additional suggestions.