

**This is a controlled document.**

Hardcopy to be endorsed by authorized person.

Check with Issuing Office or SAP system for latest update.

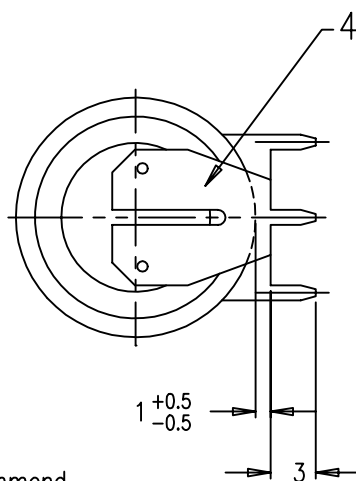
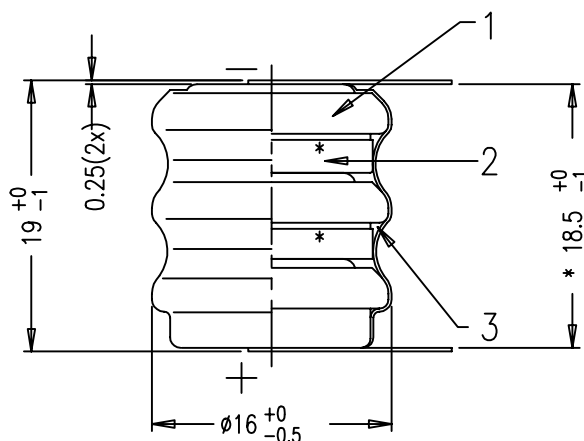
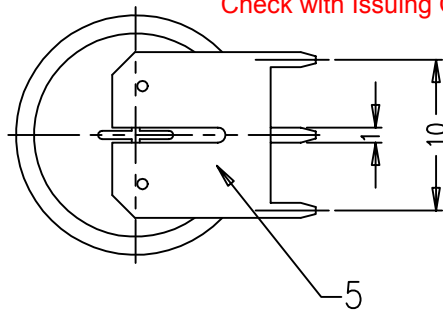

- Note: 1) No welding onto the groove  
 2) For typical PCB-application we recommend to use VARTA-Mempac batteries  
 3)\* For reference only

No.	Alterations:	Date:	Name:	Dimensions in mm	Material:
1	AO 210/99; To change the spec. of battery height	1997-07-01	Titis WS	Tolerance: DIN 7168 Medium	Refer to part list no : 070777
				Projection:	Description:  3/V80H battery with shrink sleeve & solder tags
				Scale: 2 : 1	
				Date: 1997-05-14 Name: A.P. ANG	
				Prepared: 1997-05-14 Approved: 2000-	
RIGHTS RESERVED TO MAKE TECHNICAL CHANGES, AS A RESULT OF FURTHER DEVELOPMENT, WITHOUT NOTICE . THIS DRAWING IS THE PROPERTY OF VARTA BATTERIES PTE LTD AND MUST NOT BE COPIED OR DISCLOSED TO A THIRD PARTY WITHOUT THE WRITTEN CONSENT OF VARTA BATTERIES PTE LTD.					Dwg. No: 070777
					VKB Order No: 55608 303 059
					Orig No:
Distribution: 0, 1, 1.1, 2, 2.1, 2.2, 3, 3.1, 3.1.1, 3.2, 3.3, 3.4, 4 .					

4 0 1