

# Chip Coils for Choke Wire Wound Type



## LQH32C\_23/LQH32C\_33 Series (1210 Size)

LQH32C\_23/\_33 series consists of miniature chip coils with low DC resistance, high current capacity, and high inductance characteristics. These features are made possible by the development of Murata's innovative automatic wire wound techniques.

### ■ Dimensions

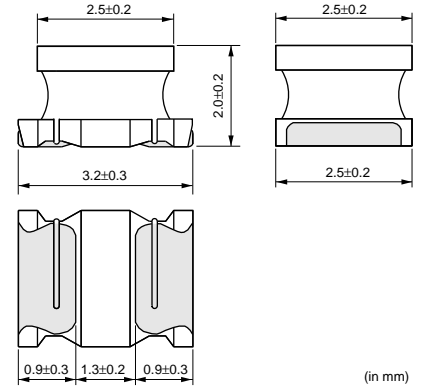

### ■ Features

1. Low DC resistance, high rated current and high inductance. Inductance: 0.15 to 560 micro H.
2. The series exhibits low voltage drops and small variations in inductance with respect to temperature rise and DC current level. This makes them excellent for use as power supply line choke coils.
3. The series has excellent solder heat resistance. Both flow and reflow soldering methods can be employed.

### LQH32C\_23 Series

#### ■ Rated Value (□: packaging code)

Part Number	Inductance	Test Frequency	Rated Current	DC Resistance	Self Resonance Frequency (min.)
LQH32CN1R0M23□	1.0μH±20%	1MHz	800mA	0.09ohm±30%	96MHz
LQH32CN2R2M23□	2.2μH±20%	1MHz	600mA	0.13ohm±30%	64MHz
LQH32CN4R7M23□	4.7μH±20%	1MHz	450mA	0.2ohm±30%	43MHz
LQH32CN100K23□	10μH±10%	1MHz	300mA	0.44ohm±30%	26MHz
LQH32CN220K23□	22μH±10%	1MHz	250mA	0.71ohm±30%	19MHz
LQH32CN470K23□	47μH±10%	1MHz	170mA	1.3ohm±30%	15MHz
LQH32CN101K23□	100μH±10%	1MHz	100mA	3.5ohm±30%	10MHz
LQH32CN221K23□	220μH±10%	1MHz	70mA	8.4ohm±30%	6.8MHz
LQH32CN331K23□	330μH±10%	1MHz	60mA	10ohm±30%	5.6MHz
LQH32CN391K23□	390μH±10%	1MHz	60mA	17ohm±30%	5MHz
LQH32CN471K23□	470μH±10%	1kHz	60mA	19ohm±30%	5MHz
LQH32CN561K23□	560μH±10%	1kHz	60mA	22ohm±30%	5MHz

Operating Temperature Range: -40°C to +85°C

### LQH32C\_33 Series (Low DC Resistance Type)

#### ■ Rated Value (□: packaging code)

Part Number	Inductance	Test Frequency	Rated Current	DC Resistance	Self Resonance Frequency (min.)
LQH32CNR15M33□	0.15μH±20%	1MHz	1450mA	0.028ohm±30%	400MHz
LQH32CNR27M33□	0.27μH±20%	1MHz	1250mA	0.034ohm±30%	250MHz
LQH32CNR47M33□	0.47μH±20%	1MHz	1100mA	0.042ohm±30%	150MHz
LQH32CN1R0M33□	1.0μH±20%	1MHz	1000mA	0.06ohm±30%	100MHz
LQH32CN2R2M33□	2.2μH±20%	1MHz	790mA	0.097ohm±30%	64MHz
LQH32CN4R7M33□	4.7μH±20%	1MHz	650mA	0.15ohm±30%	43MHz
LQH32CN100K33□	10μH±10%	1MHz	450mA	0.3ohm±30%	26MHz

Operating Temperature Range: -40°C to +85°C