

CHEVRON SHAFT FOR SEALING AND SMOOTH CONSISTENT TORQUE.

UN AXE DE COMMANDE À CHEVRONS POUR GARANTIR UNE EXCELLENTE ÉTANCHÉITÉ ET UN COUPLE RÉGULIER.

DER VORTEIL DER CHEVRON ACHSE IST EINE HOHE DICHTIGKEIT UND EIN GLEICHMÄßIGES DREHMOMENT.

UNIQUE 'T' SLIDER BLOCK FOR EXCELLENT STABILITY AND SETABILITY.

PORTE CURSEUR MONOBLOC EN 'T' POUR ASSURER LA STABILITÉ ET LA FINESSE DE RÉGLAGE.

DER 'T' SLIDER BLOCK GARANTIERT EINE HERVORRAGENDE STABILITÄT UND EINSTELLBARKEIT.

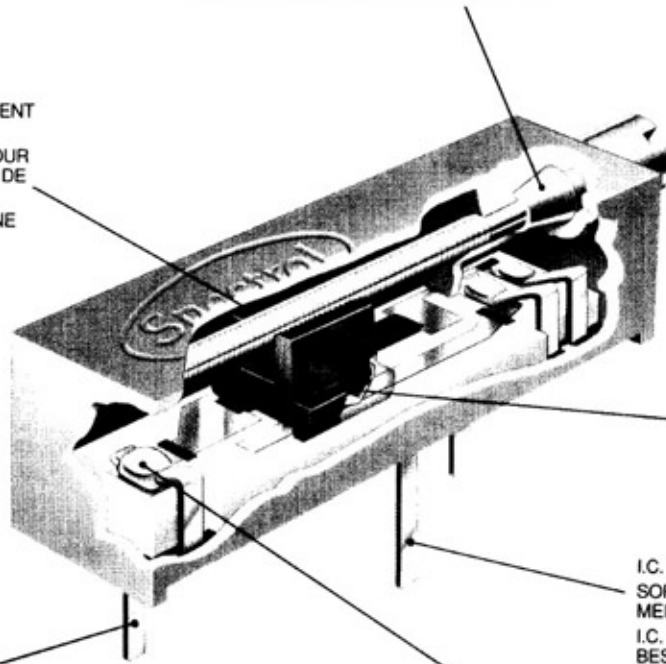

MULTIFINGER WIPER FOR BETTER C.R.V.
CURSEUR MULTIBRINS POUR UNE MEILLEURE VARIATION DE RÉSISTANCE DE CONTACT.

DER MULTIFINGER STEHT FÜR EINE SICHERE ABTASTUNG.

I.C. STYLE PINS FOR EASIER BOARD INSERTION.
SORTIES TYPE "CIRCUITS INTÉGRÉS" POUR UNE MEILLEURE INSERTION.

I.C. ANSCHLUß FORM GARANTIERT EINE LEICHTE BESTÜCKUNG.

SOLDER PLATED TERMINALS FOR GOOD SOLDERABILITY.
SORTIES PRÉ-ÉTAMÉES POUR UNE BONNE SOUDABILITÉ.
VERZINNTE ANSCHLUßPINS UNTERSTÜTZEN EINE HÖHERE LÖTSICHERHEIT.

SOLDERED TERMINATIONS FOR IMPROVED RELIABILITY.
POINTS DE LIAISON SOUDÉS POUR UNE FIABILITÉ ACCRUE.
INTERN GELÖTETE ANSCHLUßPINS SORGEN FÜR EINE HÖHERE SICHERHEIT.

A $\frac{3}{4}$ " (19mm) rectangular multiturn cermet trimmer Une Multi-Tour Rectangulaire Cermet Trimmer 19mm Ein 19mm Rechteckiger Mehr-Gang Cermit Trimmer

- Optional features • Panel mount • Clear lid • Alternative adjuster heights
- Options • montage panneau • boîtier transparent • hauteur de réglage variable
- Optionen • Front Montage • Klarsichtgehäuse • Verschiedene Aufbauhöhen

The Model 43 is manufactured to the highest international standards, approved to CECC.41101-801. This product, sealed to 85°C for 1 min. (IEC.68-2-17) has an effective electrical travel of 20 turns nominal and a resistance range of 10 ohms to 2 Megohms.

Le modèle 43 est fabriqué suivant les standards internationaux les plus élevés, est qualifié suivant la norme européenne CECC 41101-801. Ce produit, étanche pendant une minute à +85°C (norme IEC 68-2-17), a une course électrique réglable sur 20 tours et une gamme résistive de 10 ohms à 2 Megohms.

Das Modell 43 wird nach den höchsten internationalen Standards gefertigt (Prüfprotokoll CECC 41101-801). Dieses Erzeugnis – Dichtigkeit nach IEC 68-2-17 (85°C für 1 Min.) – hat eine elektrische Auflösung von nominal 20 Umdrehungen. Sie erhalten Widerstandswerte von 10 ohm bis 2 Mohm.

MODEL 43 10 ohms to 2 Megohms

TRIMMING POTENTIOMETER

ELECTRICAL

EFFECTIVE ELECTRICAL TRAVEL	20 turns nominal
RESISTANCE RANGE	10 ohms to 2 megohms
RESISTANCE TOLERANCE	±10%
END RESISTANCE	2 ohms maximum
TEMPERATURE COEFFICIENT OF RESISTANCE	±100 PPM/°C, 100 ohms to 2 megohms; - 100 to +200 PPM/°C, 10 ohms, 20 ohms and 50 ohms
POWER RATING	0.5 watt at 70° C derated linearly to zero watts at 125° C. Maximum voltage not to exceed 400V
DIELECTRIC WITHSTANDING VOLTAGE	1000V AC at sea level, 250V AC at 80000 feet (24400 metres)
INSULATION RESISTANCE	1000 megohms minimum
CONTACT RESISTANCE VARIATION	1% or 1 ohm, whichever is greater

MECHANICAL

STOPS	Wiper idles against stops
OPERATING TORQUE	22.5 mNm Max
ROTATIONAL LIFE	200 cycles minimum with a maximum change of ±2% in total resistance
WEIGHT	0.04oz (1.2gm) maximum
RESISTANCE ELEMENT	Cermet
SETABILITY	±0.05% R.T.

RESISTANCE VALUES - OHMS

10R, 20R, 50R, 100R, 200R, 500R, 1k, 2k, 5k, 10k, 20k, 25k, 50k, 100k, 200k, 250k, 500k, 1M, 2M.

MARKING

Manufacturer's name and part number, EIA resistance code, BS resistance code, date code, terminal identification

ENVIRONMENTAL

		MAX CHANGE	
		ΔR	$\frac{V_{ab}}{V_{ac}}$
CHANGE OF TEMPERATURE	-55° C to +125° C	2%	1%
BUMP	390m/s ² 4000	1%	-
VIBRATION	98m/s ² 10 to 500 Hz	1%	2%
ELECTRICAL ENDURANCE	1000 hour	3%	-
SOLDERING	-	-
RESISTANCE TO HEAT	1%	-
DAMP HEAT STEADY STATE	21 days	3%	-
SEALING	85° C for 1 min	-	-
MECHANICAL LIFE	200 cycles	3%	-
TERMINAL STRENGTH	2.2lbs (1kg)	min	-

RELATED DOCUMENTS

1	PER CECC 41100	2	PER IEC 68.1 PART	3	PER MIL 202F
---	----------------	---	-------------------	---	--------------

ORDERING CODES:

STANDARD	43P-XXX
CLEAR LID	43PT040-XXX
PANEL MOUNT	43PT601-XXX

1	2	3
(PARA 2.3.6)	TEST NA (IEC 68-2-14)	METHOD 107
(PARA 2.3.3)	TEST EB (IEC 68-2-29)	NO EQUIVALENT
(PARA 2.3.2)	TEST FC (IEC 68-2-6)	METHOD 204
(PARA 2.5.16)	NO EQUIVALENT
(PARA 2.3.7)	TEST T (IEC 68-2-20)	METHOD 208
(PARA 2.3.7)	TEST TB (IEC 68-2-20A)	METHOD 210
	METHOD 1A	
(PARA 2.1)	TEST C (IEC 68-2-3)	METHOD 103
AS IEC	TEST QC (IEC 68-2-17)	METHOD 112
	METHOD 2	

BASE RISER	0.24 (6.1)	43 PT602-XXX
BASE RISER	0.28 (7.1)	43 PT607-XXX

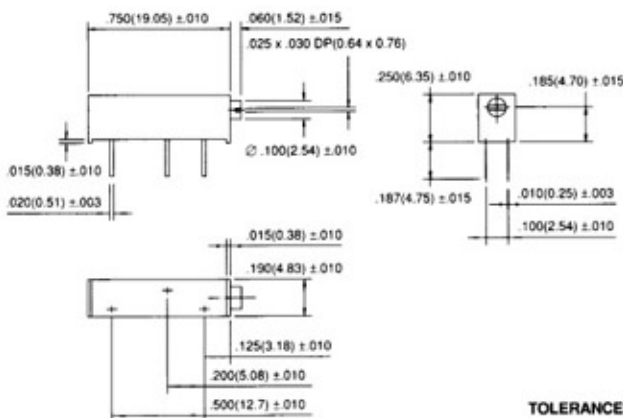

43P & 43P T040

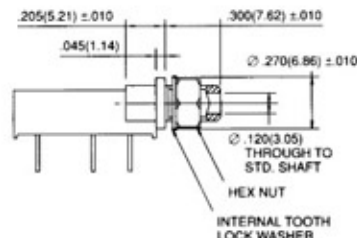

43PT601

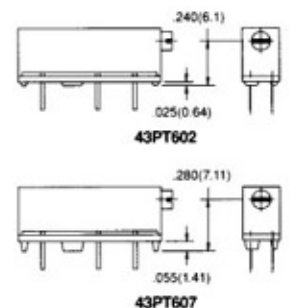

43PT602

43PT607

TOLERANCES: UNLESS OTHERWISE NOTED
DECIMALS ±.005 ANGLES ±2°
DIMENSIONS: IN (MM)



As a general policy Spectrol does not recommend the use of any of its products in life support applications where failure or malfunction of the Spectrol product can be reasonably expected to cause failure of the life support device or to significantly affect its safety or effectiveness.