

LOC		DIST		P		F		ZONE		LTR		REVISIONS		DATE	APPD	
CM	53												AK	REVISED PER EC 063B-0224-02	26-APR-02	KW

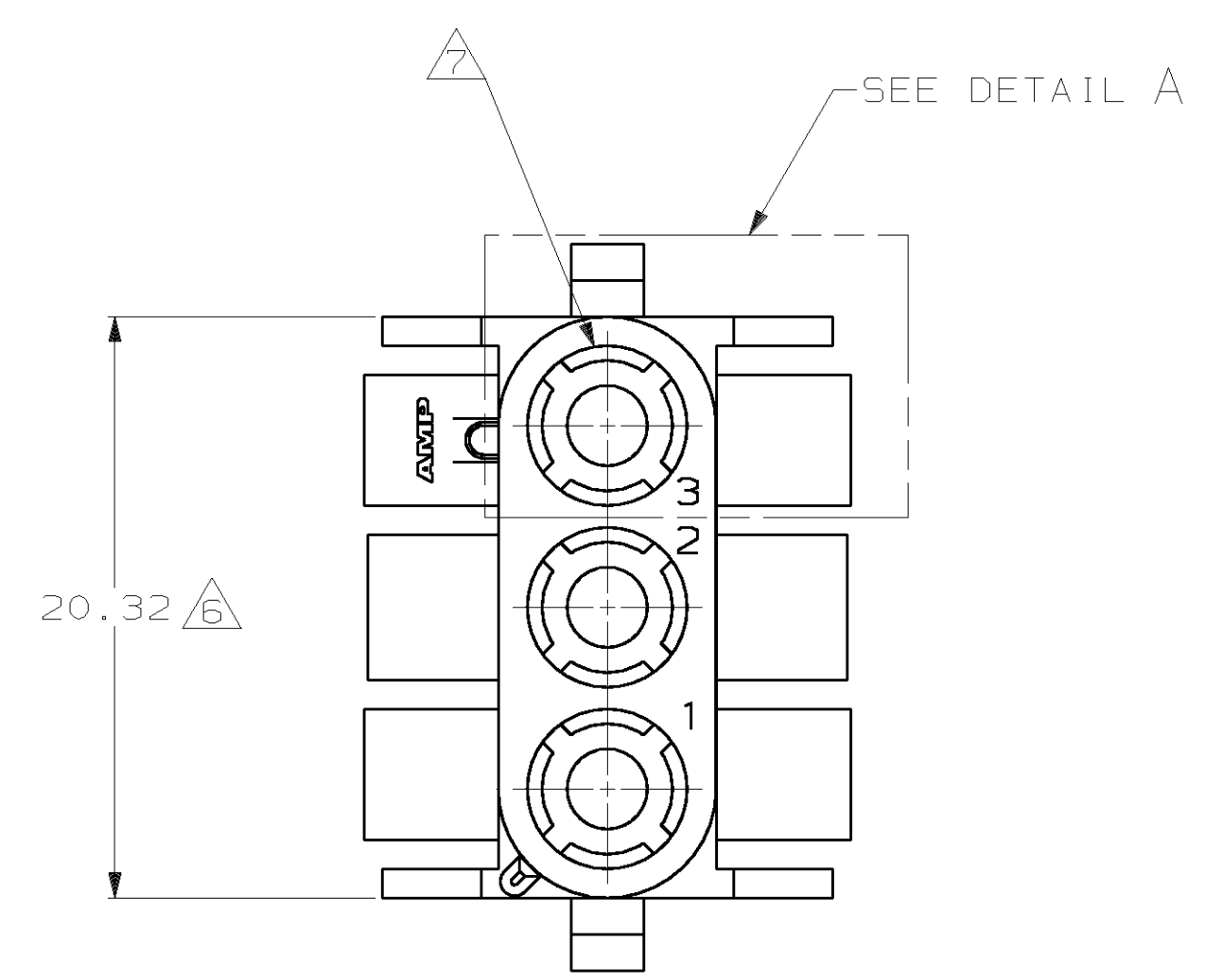

- MATES WITH APPROPRIATE UNIVERSAL MATE-N-LOK™ PLUG.
- RECOMMENDED PANEL THICKNESS 0.76 - 2.29.
- PANEL MUST BE PUNCHED SO THAT THE HOUSING ENTERS THE PANEL IN THE SAME DIRECTION AS THE PUNCH.

- △4 OPTIONAL FOR KEYING HOUSING IN PANEL.
- △5 CIRCUIT NUMBER 1 LOCATION.
- △6 DIMENSION INDICATED IS AS MOLDED. ADDITIONAL GROWTH DUE TO SUBSEQUENT MOISTURE ABSORPTION MAY OCCUR.
- △7 FOUR RIBS EQUALLY SPACED, NO SPECIFIC ORIENTATION. NO RIBS OR SIX RIBS EQUALLY SPACED, NO SPECIFIC ORIENTATION, OPTIONAL.
- △8 UNDERWRITERS RECOGNIZED COMPONENT LOGO AND CSA CERTIFICATION LOGO TO BE LOCATED ONCE EACH ON SIDE OF HOUSING.

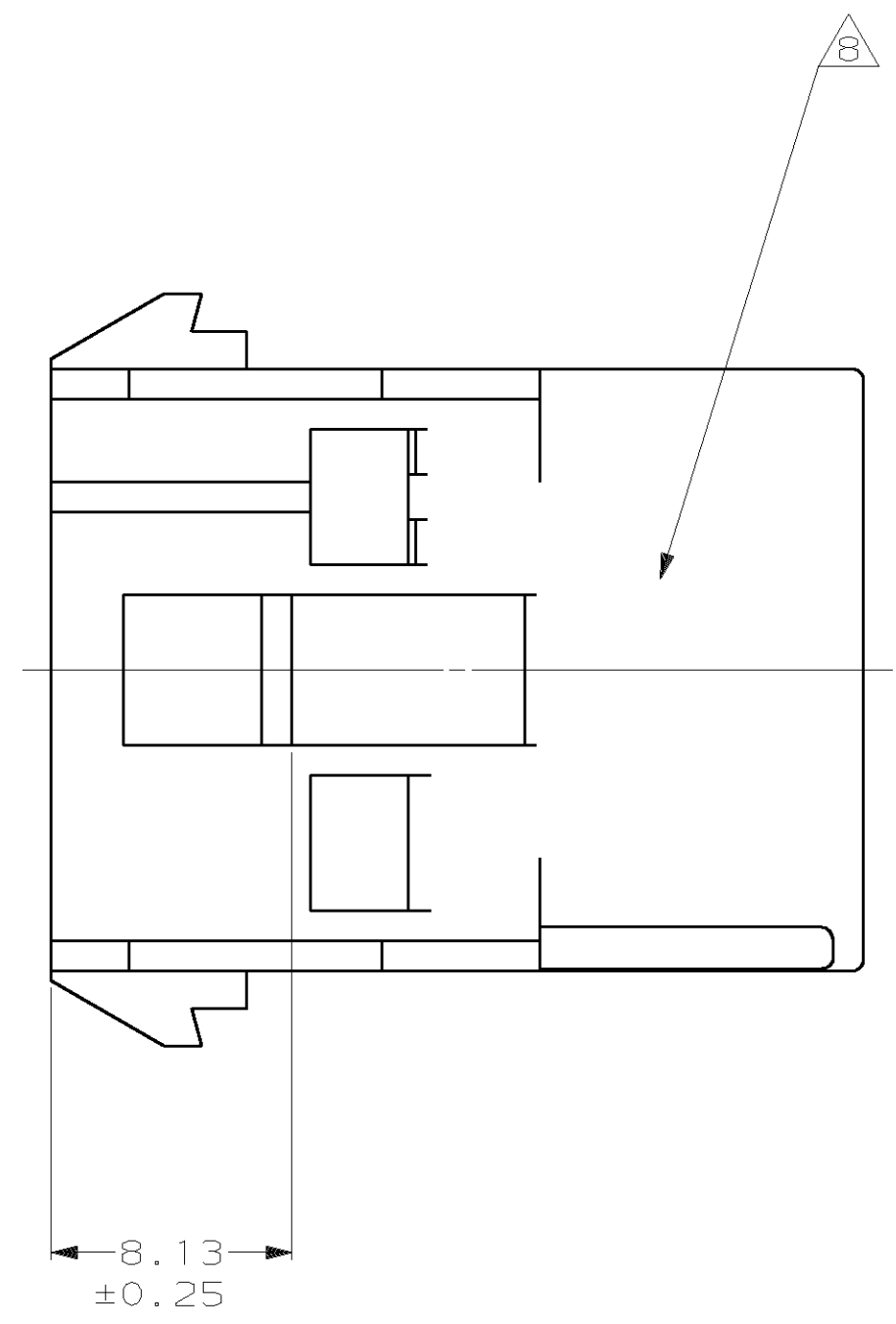
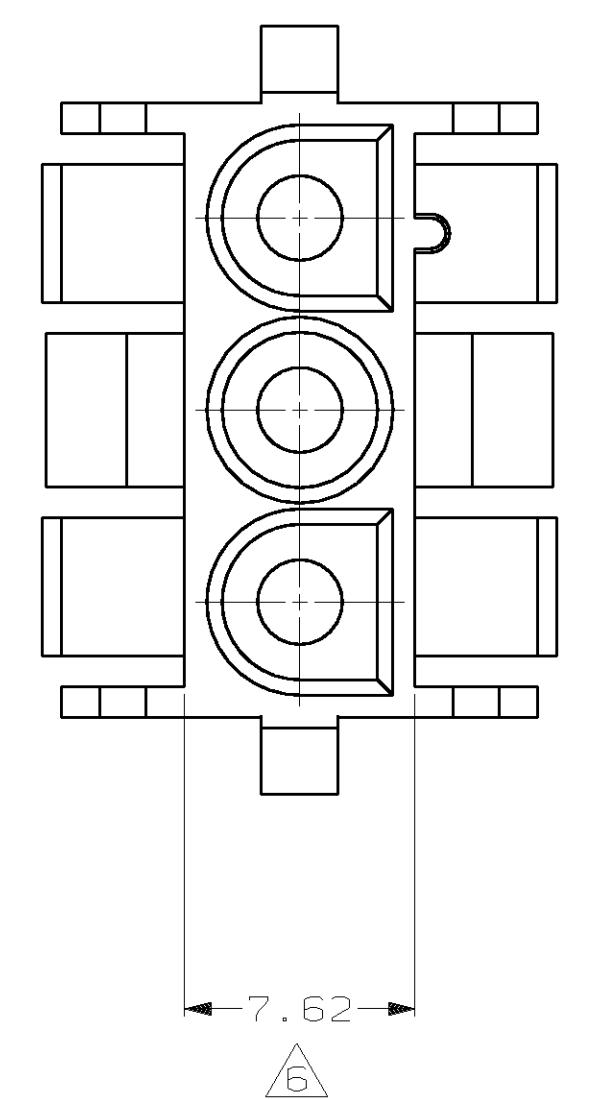
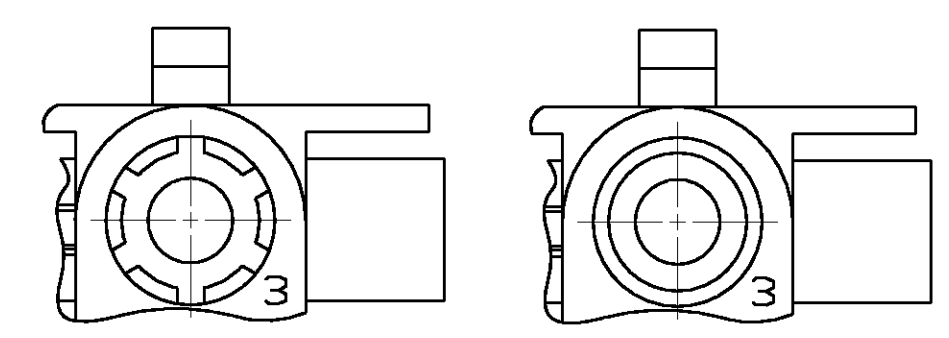

DETAIL A
OPTIONAL CONSTRUCTIONS

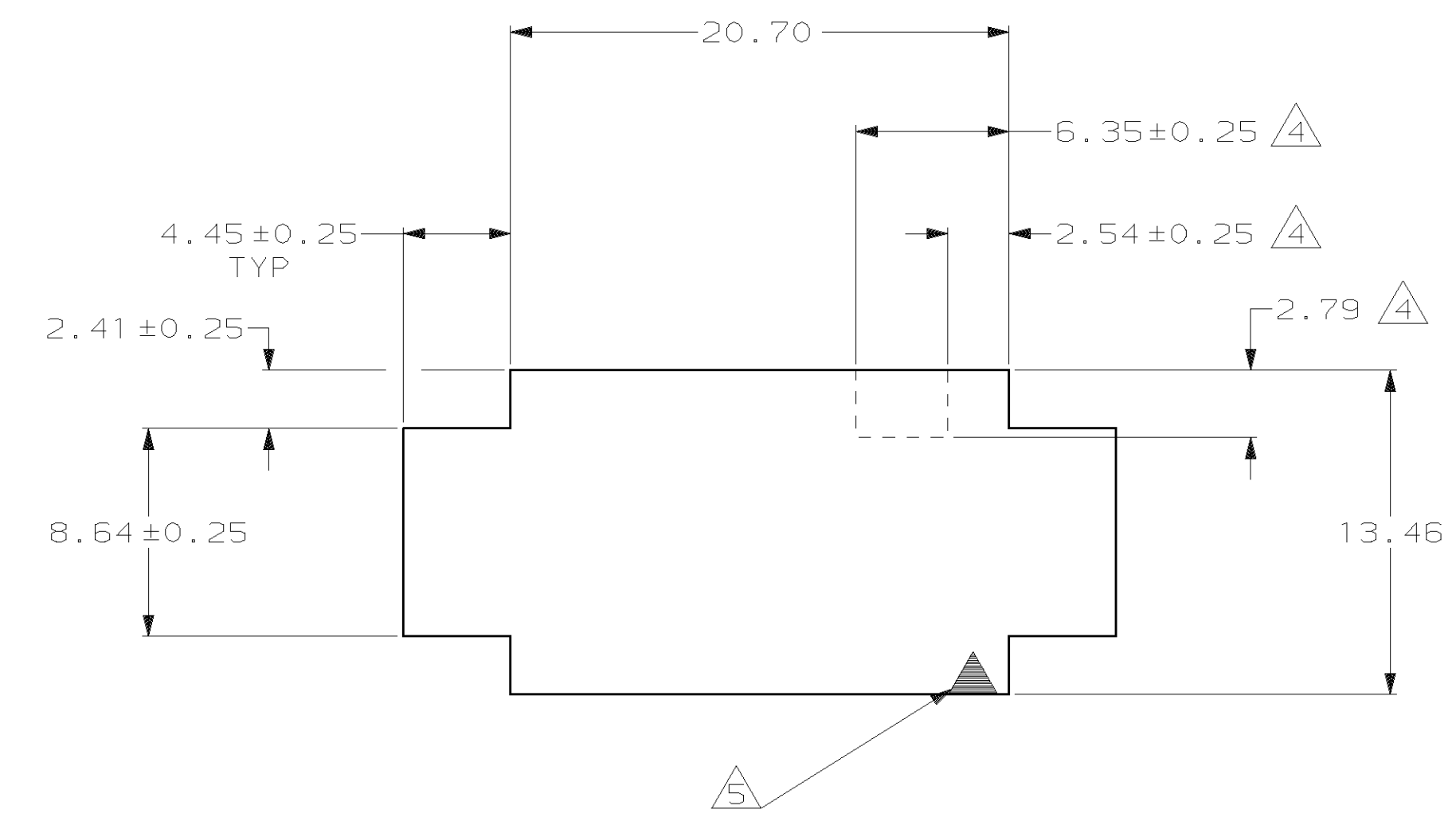
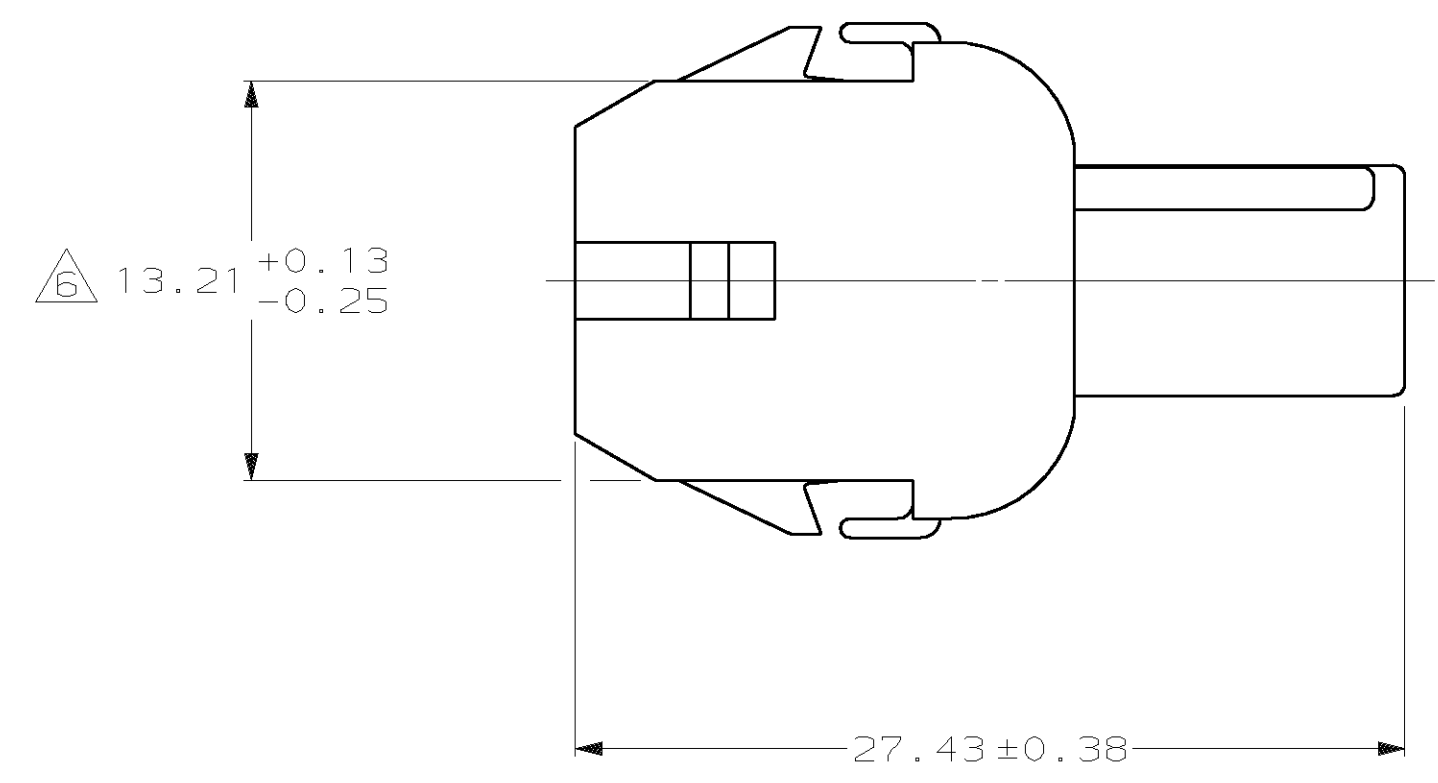

RECOMMENDED PANEL CUT OUT

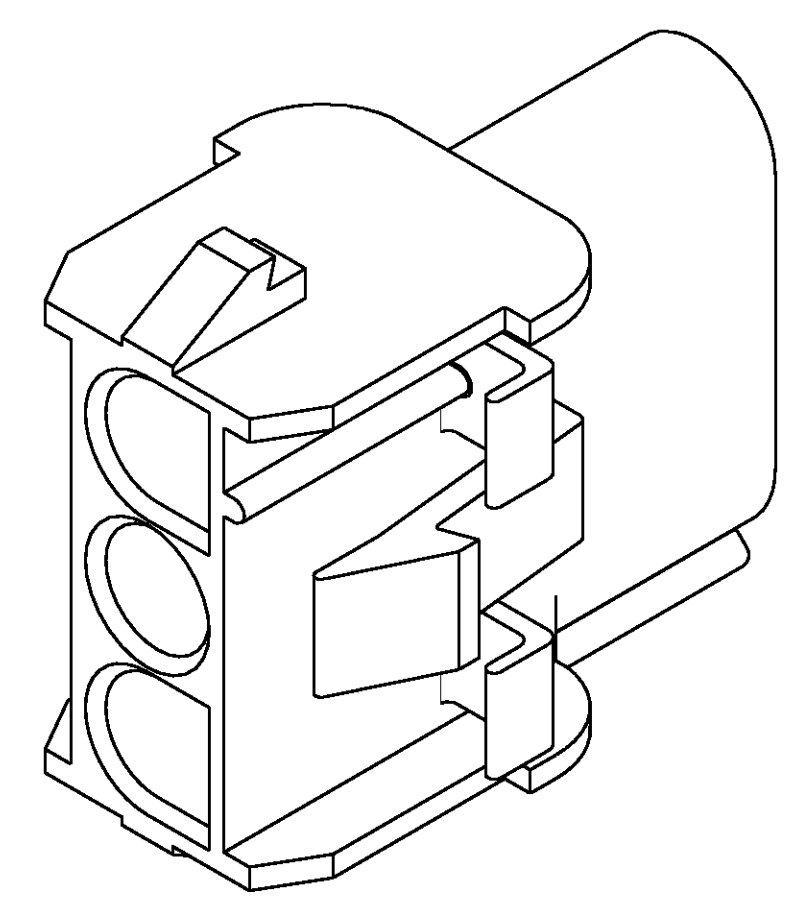

3-DIMENSIONAL MODEL
NTS

MM	IN	MM	IN
4.45	.175	27.43	1.080
2.79	.110	20.70	.815
2.54	.100	20.32	.800
2.41	.095	13.46	.530
2.29	.090	13.21	.520
0.76	.030	8.64	.340
0.38	.015	8.13	.320
0.25	.010	7.62	.300
0.13	.005	6.35	.250
MM	IN	MM	IN

CONVERSION TABLE

METRIC

THIS DRAWING IS A CONTROLLED DOCUMENT FOR AMP INCORPORATED. IT IS SUBJECT TO CHANGE AND THE CONTROLLING ENGINEERING ORGANIZATION SHOULD BE CONTACTED FOR THE LATEST REVISION.

DO NOT SCALE PRINT. UNLESS SPECIFIED DIMENSIONS IN mm (INCHES) TOLERANCES ON: 2 PLC DEC ± 0.13 3 PLC DEC ± - ANGLES ± 1°0'	DR 7-20-92 K. WHITAKER CHK 7-20-92 R. SWING APPD 7-21-92 D. SELF APPD 7-21-92 D. SELF
MATERIAL NYLON, UL 94V-2	PRODUCT SPEC -
FINISH -	APPLICATION SPEC -
WEIGHT -	

BLACK	1-480701-9
BLUE	1-480701-6
GREEN	1-480701-5
RED	1-480701-2
BROWN	1-480701-1
NATURAL	1-480701-0
COLOR	PART NO

AMP AMP Incorporated Harrisburg, PA 17105-3608	
NAME CAP, 3 CIRCUIT, UNIVERSAL MATE-N-LOK™	
SIZE D	CAGE CODE 00779
DRAWING NO C-480701	SHEET 1 OF 2
SCALE 4:1	

LOC		DIST		P		F		ZONE		LTR		REVISIONS		
CM	53											DESCRIPTION	DATE	APPD
												AK SEE SHEET 1	-	-

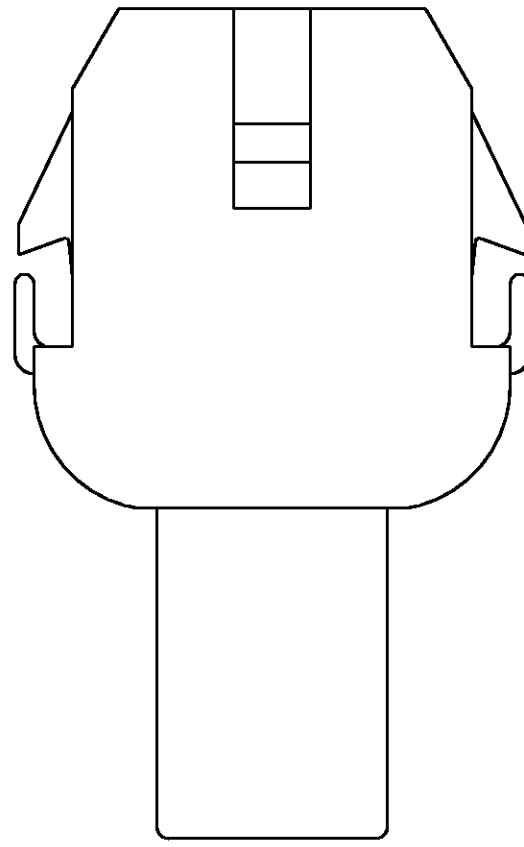

1. STAMP NUMBERS 3.18 HIGH AT WIRE END OF HOUSING (12 POINT DAVID TYPE).
2. CHARACTERS TO BE STAMPED ON HOUSING IN A MANNER AS TO BE READ FROM WIRE END ONLY.
3. VIOLET, BLACK, BROWN, AND BLUE COLORED BLOCKS TO BE STAMPED WITH WHITE CHARACTERS. ALL OTHER COLORED BLOCKS TO BE STAMPED WITH BLACK CHARACTERS.

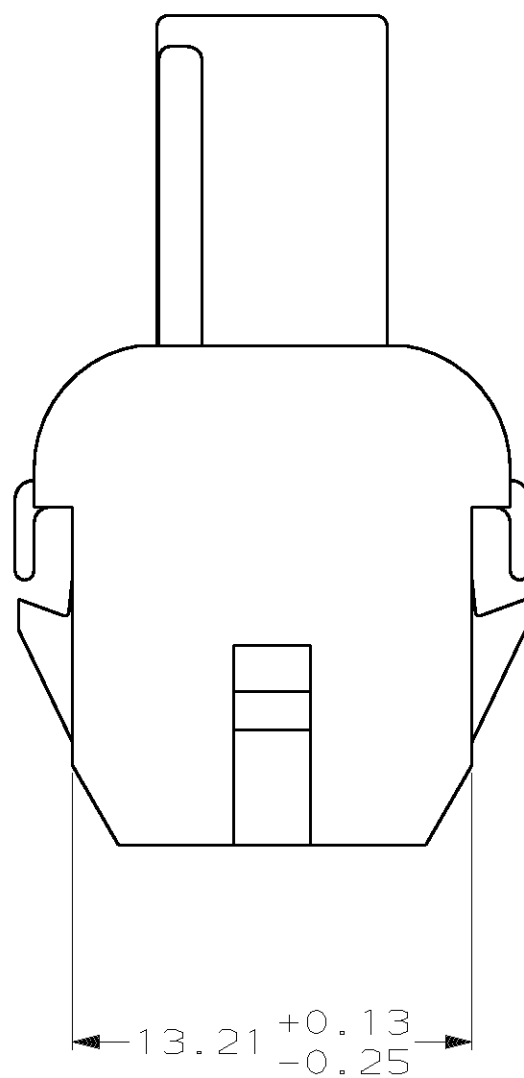
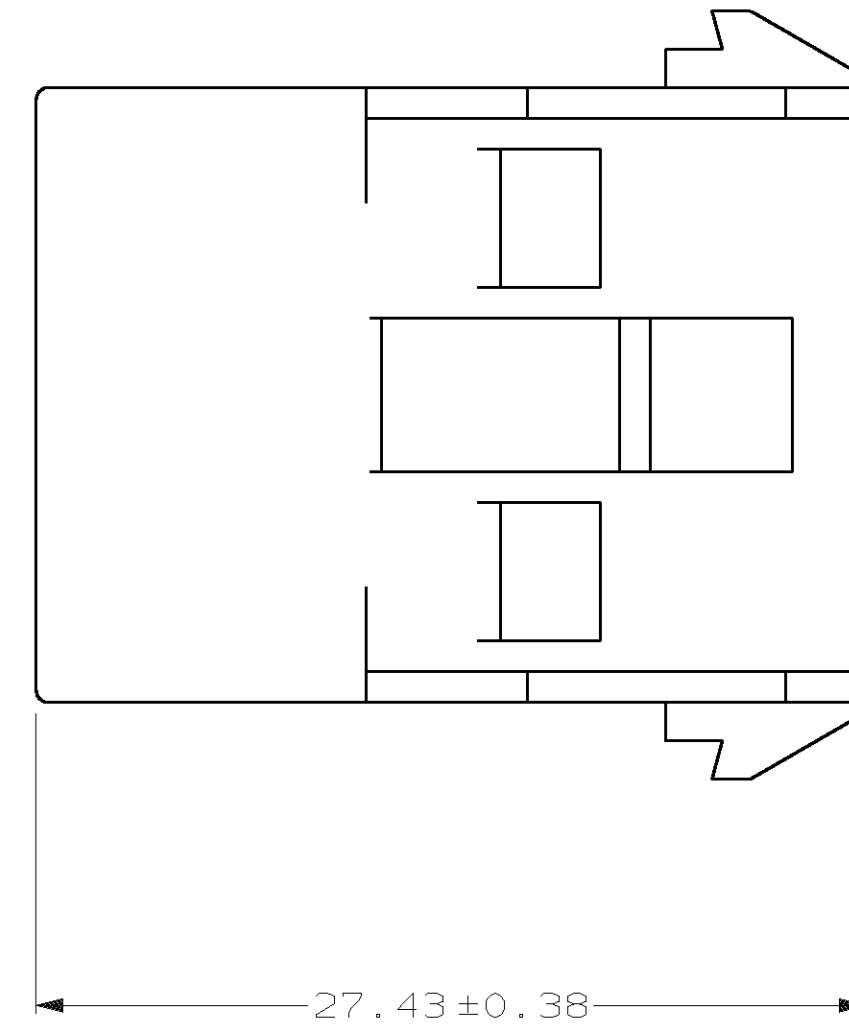
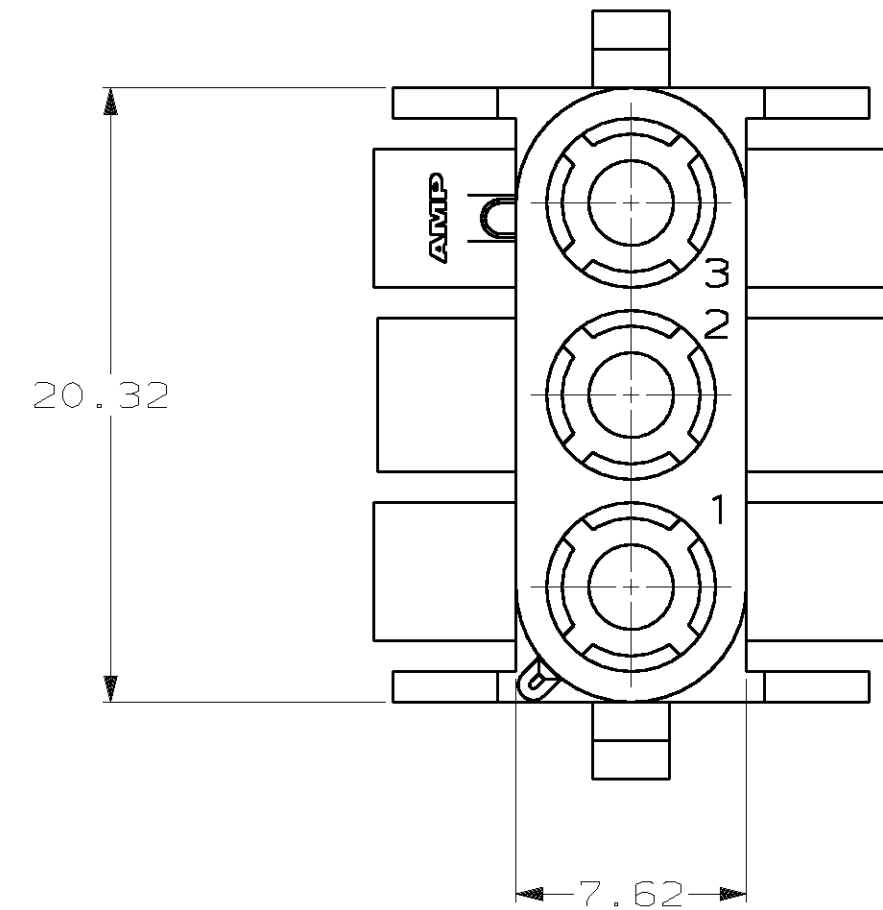
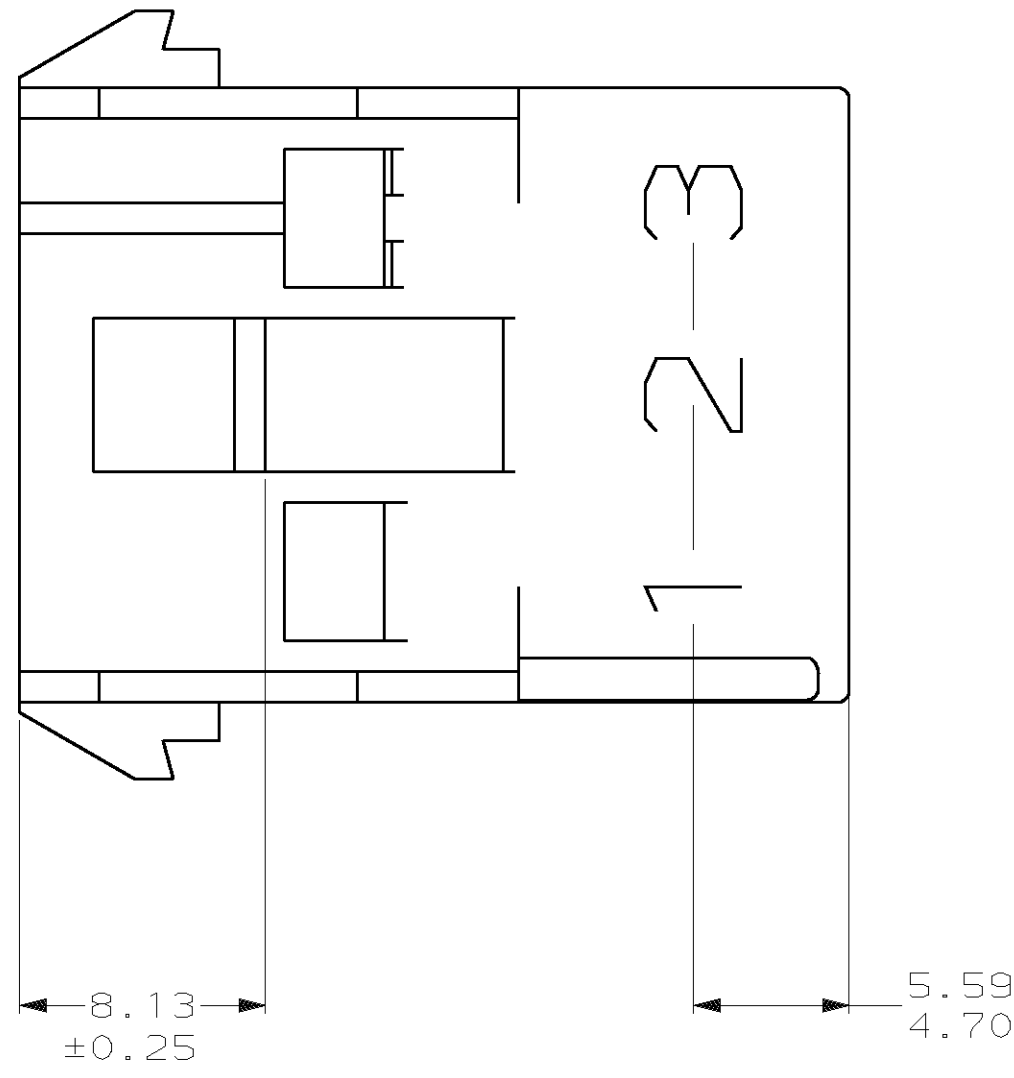

MM	IN	MM	IN
5.59	.220	-	-
4.70	.185	27.43	1.080
3.18	.125	20.32	.800
0.38	.015	13.21	.520
0.25	.010	8.13	.320
0.13	.005	7.62	.300

CONVERSION TABLE

METRIC

THIS DRAWING IS A CONTROLLED DOCUMENT FOR AMP INCORPORATED. IT IS SUBJECT TO CHANGE AND THE CONTROLLING ENGINEERING ORGANIZATION SHOULD BE CONTACTED FOR THE LATEST REVISION.

DO NOT SCALE PRINT. UNLESS SPECIFIED DIMENSIONS IN mm (INCHES)		DR 7-20-92 K. WHITAKER	NATURAL		2-480701-0	
TOLERANCES ON:		CHK 7-20-92 R. SWING	COLOR	PART NO		
2 PLC DEC ± 0.13		APPD 7-21-92 D. SELF	AMP Incorporated Harrisburg, PA 17105-3608			
3 PLC DEC ± -		APPD 7-21-92 D. SELF	NAME			
ANGLES ± 1°0'		PRODUCT SPEC	CAP, 3 CIRCUIT, UNIVERSAL MATE-N-LOK™			
MATERIAL		APPLICATION SPEC	SIZE	CAGE CODE	DRAWING NO	
-		WEIGHT	D	00779	C-480701	
FINISH			SCALE	4:1	SHEET 2 OF 2	
-			CUSTOMER DRAWING			