

Top View of Assembly

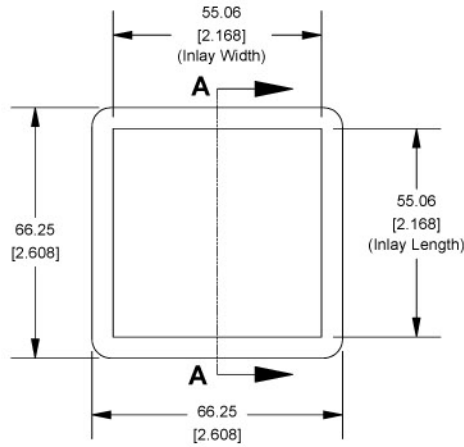

**SECTION A-A
(Side View Inside Assembly)**

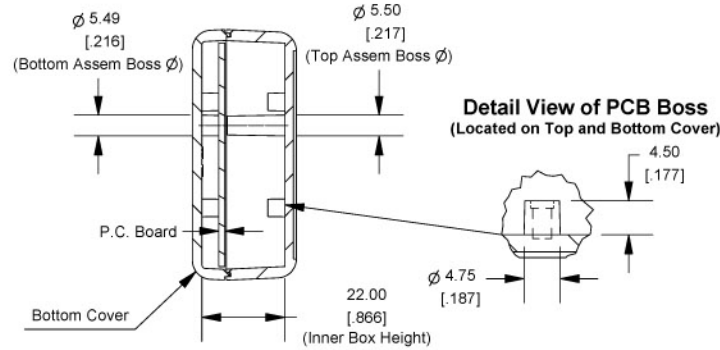

Hand Held Instrument (1593J)

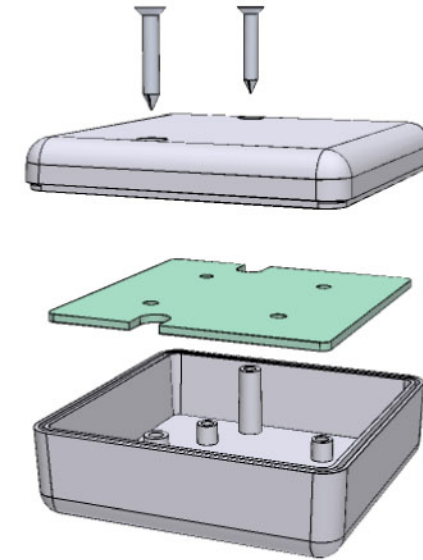

End View of Assembly

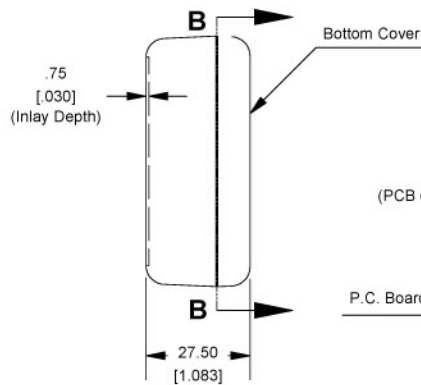

**SECTION B-B
(Inside of Bottom Cover)**

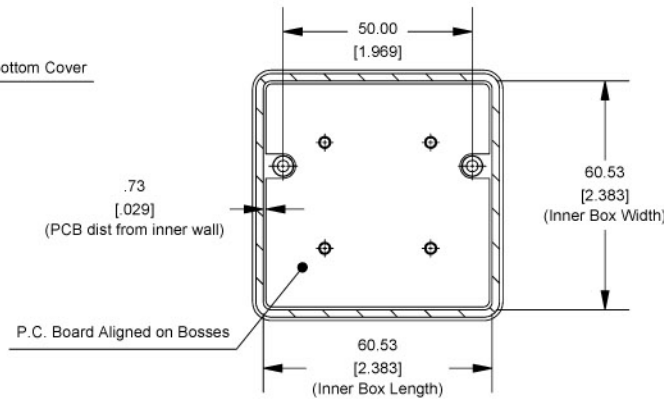

Maximum P.C. Board Size

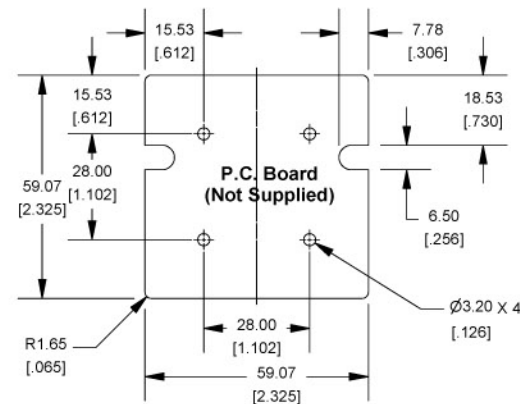

Enclosures can be Factory Modified (Milling, Drilling, Printing etc.)
Solid models of this enclosure available in STEP or IGES.
Contact Factory mjm@hammondmfg.com

NOTE	
Enclosure molded from GP ABS (UL94-HB) plastic.	
Purchased assembly includes top cover, bottom cover and 2 cover screws.	

PART NUMBERS	
1593J Enclosure	
Black Enclosure	1593JBK
Grey Enclosure	1593JGY
ACCESSORIES	
Cover Screws (Pkg 100)	1593QS100 (Silver)
#4 x 3/4" self-tapping oval head (19.1mm)	1593QS100BK (Black)
P.C. Board Screws	1593ATS50 (Pkg 50)
#4 x 1/4" self-tapping (6.4mm)	1593ATS100 (Pkg 100)
Belt or Pocket Clip	1599CLIP (Black)
	1599CLIPGY (Grey)
Infrared Panels (Pkg 10)	1593DIR10

**HAMMOND
MANUFACTURING™**

1593J

www.hammondmfg.com