

**SECTION A-A  
End View of Assembly**

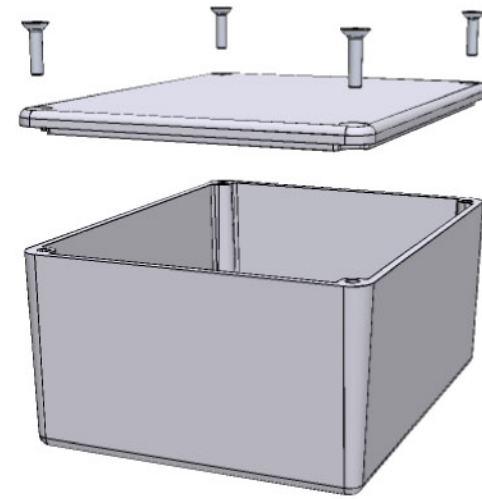

**Top View Looking Inside Box**

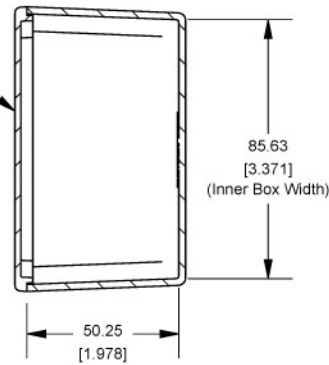
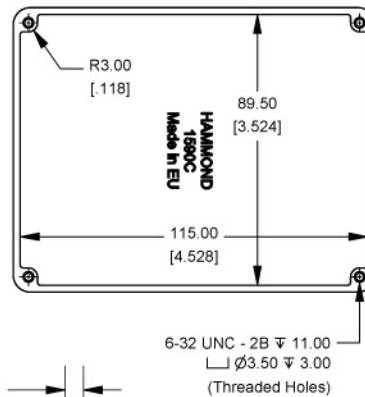

**SECTION B-B  
Side View of Assembly**

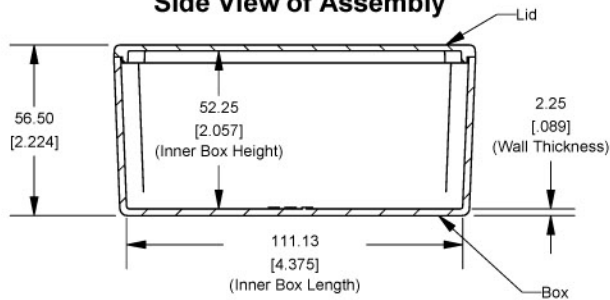

**Lid**

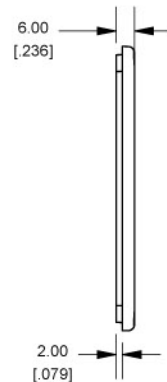
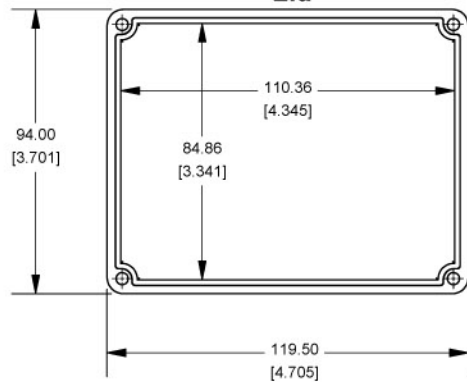

Enclosures can be Factory Modified ( Milling, Drilling, Printing etc.)  
Contact Factory [mjm@hammondmfg.com](mailto:mjm@hammondmfg.com) for quotes  
Solid models of this enclosure available in STEP or IGES.

**NOTE**

Purchased assembly includes box, lid and 4 cover screws.  
Box and lid are made from Diecast Aluminum Alloy (alloy type 380).  
Silicone Gasket Loctite #5950

**PART NUMBERS**

1590C Enclosure	
Unfinished	1590C
Grey Textured Polyester Powder Paint - RAL 7038	1590CGY
Black Textured Polyester Powder Paint - RAL 9011	1590CBK
1590C Liquid Resistant Enclosure (Silicon Factory Installed Gasket)	
Unfinished	1590WC
Black Textured Powder Paint	1590WCBK
ACCESSORIES	
Recommended Torque: 75 ozf.in / 55 cN.m	
Black Textured Cover Screws (Pkg 50) [6-32 x 1/2" SS Type 304]	1590WMS100BK
Unfinished Cover Screws (Pkg 100) [6-32 x 1/2" Nickel Plated Screws]	1590WMS100
Standard Cover Screws	
Unfinished Cover Screws (Pkg 100) [6-32 x 1/2" Nickel Plated Screws]	1590MS100
Black Textured Cover Screws (Pkg 50) [6-32 x 1/2" SS Type 304]	1590MS100BK

