

DIMENSIONS:	
A	3.125" ±0.063
B	4.186" ±0.125
C	3.800" ±0.063
D	2.500" ±0.063
E	2.938" ±0.063
G	0.203" x 0.400" ±0.015

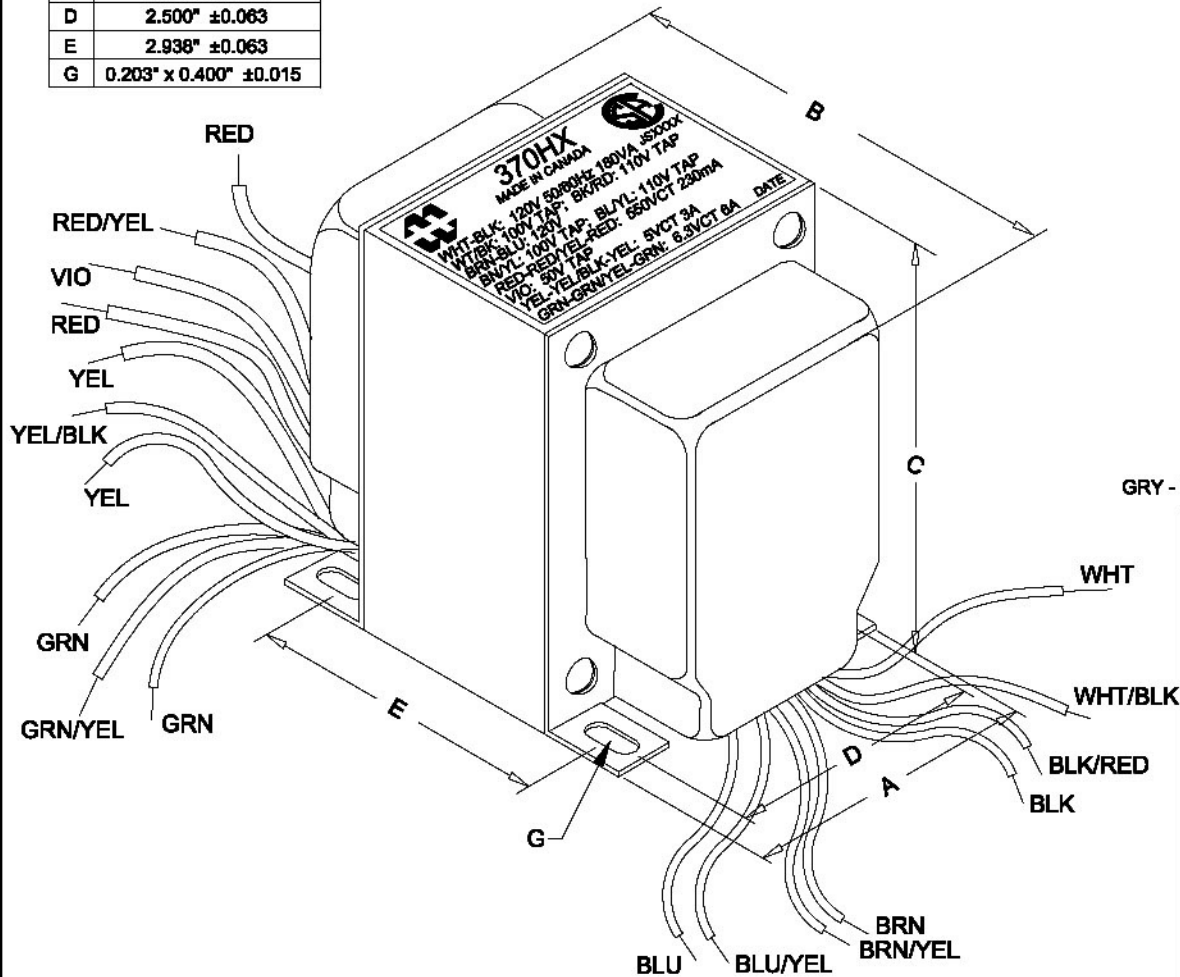

NOTE: ALL LEADS 8" OUT MIN. STRIPPED 0.5

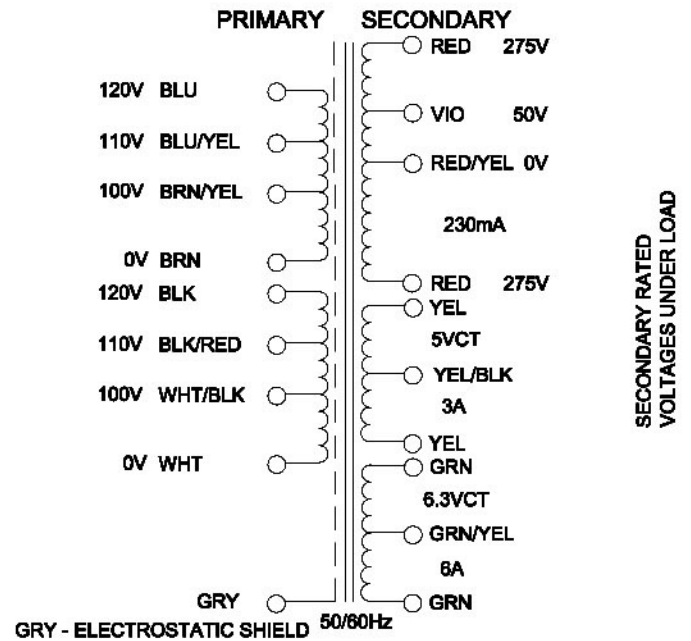

ELECTRICAL DATA:		
TESTS	CONDITIONS	ACCEPTANCE CRITERIA
I <sub>ex</sub>	@ 120V, 60Hz, WHT - BLK	221mA Max.
Sec. N.L.V	@ 120V, 60Hz, WHT - BLK	
	RED - RED =	581.8V ±2%
	RED - RED/YEL = RED/YEL - RED =	290.9V ±2%
	RED/YEL - VIO =	51.84V ±2%
	YEL - YEL =	5.760V ±2%
	YEL - YEL/BLK = YEL/BLK - YEL =	2.880V ±2%
	GRN - GRN =	6.720V ±2%
	GRN - GRN/YEL = GRN/YEL - GRN =	3.360V ±2%
DCR	@ 20°C, WHT - BLK =	3.075 Ω ±20%
	@ 20°C, BRN - BLU =	3.328 Ω ±20%
	@ 20°C, RED - RED =	71.20 Ω ±20%
	@ 20°C, YEL - YEL =	0.046 Ω ±20%
	@ 20°C, GRN - GRN =	0.035 Ω ±20%
HIPOT	PRIMARY - SECONDARY	2500V, 60Hz, 1 SEC

REV.#	REVISION	DATE
0	RELEASED.	C.I. 09/08/12



DWG. BY: C. ILIE	CHK'D BY:	TITLE: POWER TRANSFORMER	DWG. NO. 370HX
DATE: 09/08/12	APP'D. BY:		
	DIMENSIONS: IN(X) MM ( )		